

# CUTA2810113B

REVISIONS			
REV	DATE	BY	DESCRIPTION
A1	01-17-24	KD	INITIAL RELEASE

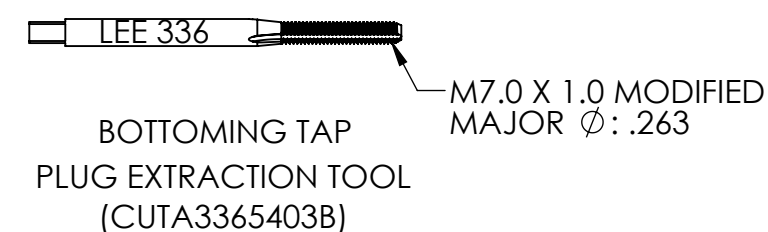
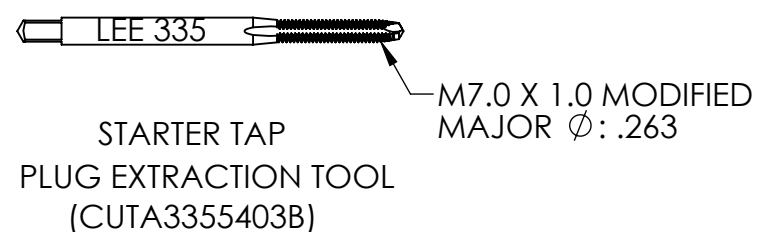
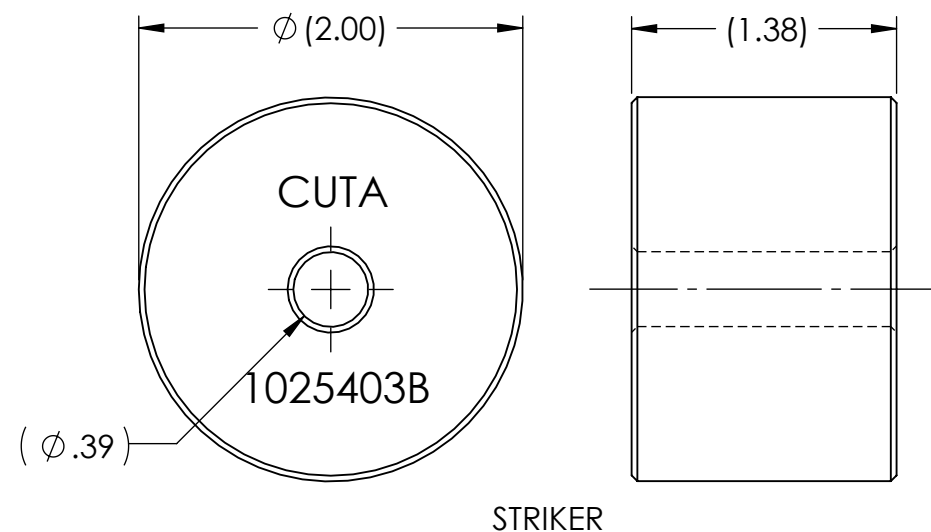
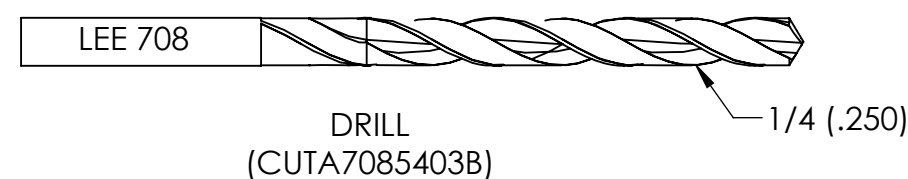
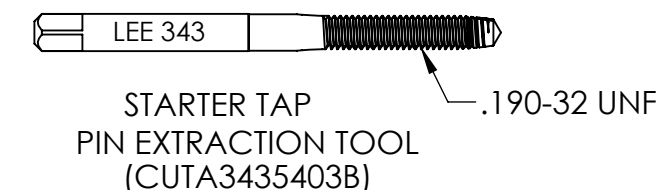
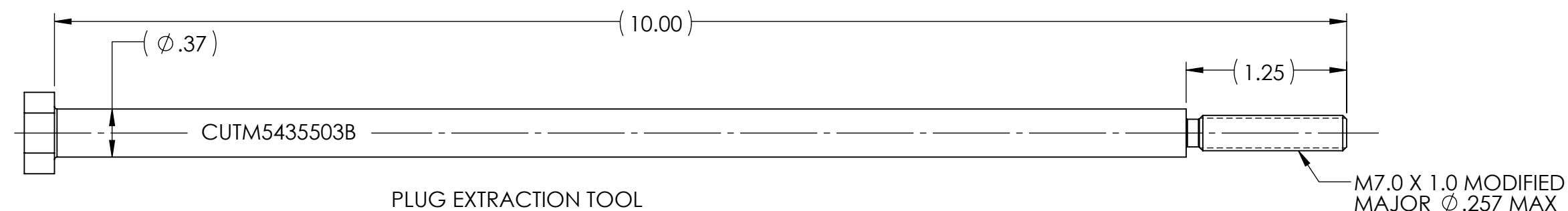
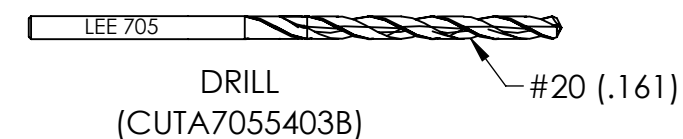
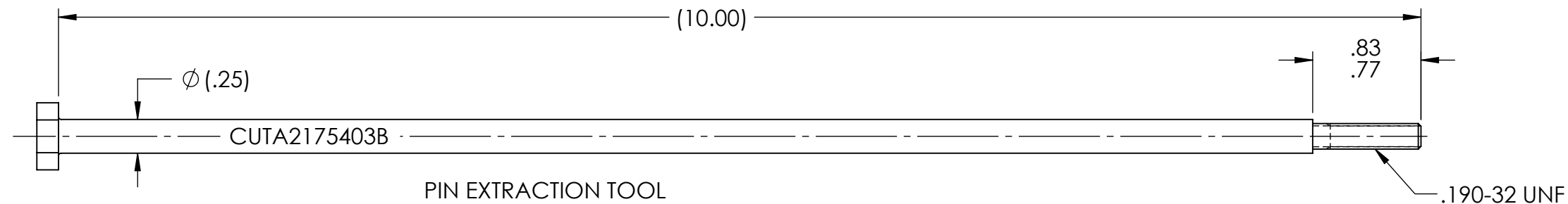

- NOTES:
- MINIMUM OF 3 THREADS OF ENGAGEMENT TO EXTRACT THE PIN AND 4 THREADS OF ENGAGEMENT TO EXTRACT THE PLUG.
  - USE DRILL CUTA7085403B TO REMOVE THE TAPER FROM THE PLUG INNER DIAMETER.
  - EXTRACTION TOOL SET FOR PLGA2811350A.

WARNING-EXPORT CONTROLLED BY: EAR [50 USC 2401], THIS DRAWING: EAR99  
PRODUCT/TECHNOLOGY CLASSIFICATION: EAR99/EAR99

**PROPRIETARY NOTICE**  
This document contains confidential, trade secret information which is proprietary to The Lee Company, and is submitted upon the express condition that neither it, nor our products, will be used directly or indirectly in any way detrimental to the interests of The Lee Company, such as disclosure to others or replication of our products, and/or in violation of 18 U.S.C. 1905 (TSA), 5 U.S.C. 552 (FOIA), E.O. 12600 of 6/23/87, 18 U.S.C. 1832, and C.G.S.A. (CT) Chapter 625 sec. 35-50 thru 35-58.

CUTD2810113  
REFERENCE

DWG. NO. CUTA2810113B	NOTES AND DIMENSIONS SHOWN HERE ON ARE FOR INSPECTION IDENTIFICATION ONLY. ALL MANUFACTURING RIGHTS RESERVED.	DRAWN	K D	01-17-24	LEE TOOL SET, MP35N EXTRACTION, .281		
	UNLESS OTHERWISE SPECIFIED EXT. COR. BREAK: INTERNAL FILLET R:  SURFACE FINISH ALL OVER DIMENSIONS ARE IN INCHES  TOLERANCES 2 PLACES 3 PLACES ANGLES $\pm .015$ $\pm .005$ $\pm 5^\circ$	CHK'D	B W	09-25-24			
		APP'D	R M	10-07-24	 <b>THE LEE COMPANY</b> WESTBROOK, CT 06498		
		MATL	H.T.	FINISH			
				SCALE NONE		SHEET 1 OF 1	