

LEE IMH 5.5 mm RELIEF VALVE REVERSE FLOW

The Lee Company's new miniature, Pop-pet-Style Pressure Relief Valve provides a faster opening rate and more stable flow than typical ball style relief valves. Measuring just 5.5 mm in diameter and 16.6 mm long, the new valve weighs only 1.7 grams.

Simple to install, the new relief valve uses our field-proven Lee Insert Principle that provides secure retention and eliminates the need for threads, O-rings, or in-house designs. To install, simply insert the relief valve into a drilled hole and drive the expansion pin flush to seal and lock the valve in place. Designed for reliable operation, the new relief valve features robust, all stainless steel construction and 100% performance testing to ensure consistent, long term performance.

The new relief valve's compact size, superior performance, and ease of installation make it ideal for high volume applications in automotive, off-road, and other industrial hydraulic systems.

- Fast Opening Rate
 - Stable Flow
 - Minimizes System Stress
- 100% Tested
 - Improves System Level Yield Rates
- Small Size
 - Saves Space and Weight
- All Stainless Steel Construction
 - Compatible With Most Fluids
- Low Hysteresis
 - Improves System Performance

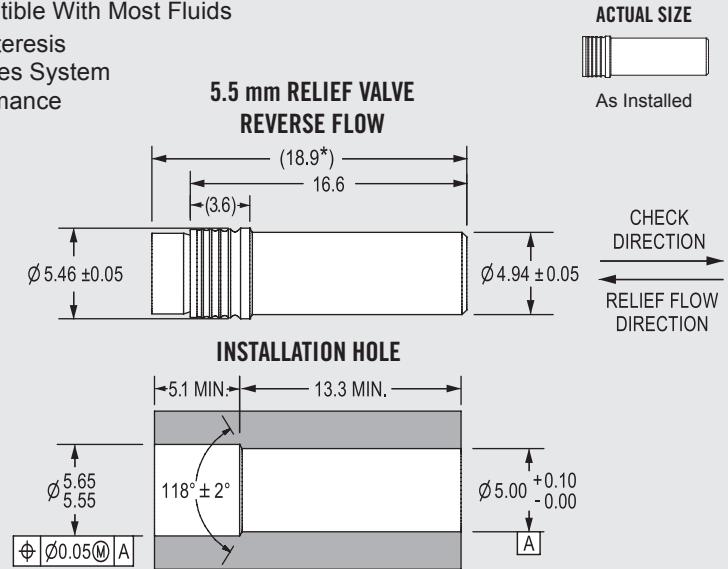

*LOA before installation. All dimensions in millimeters, except where noted.

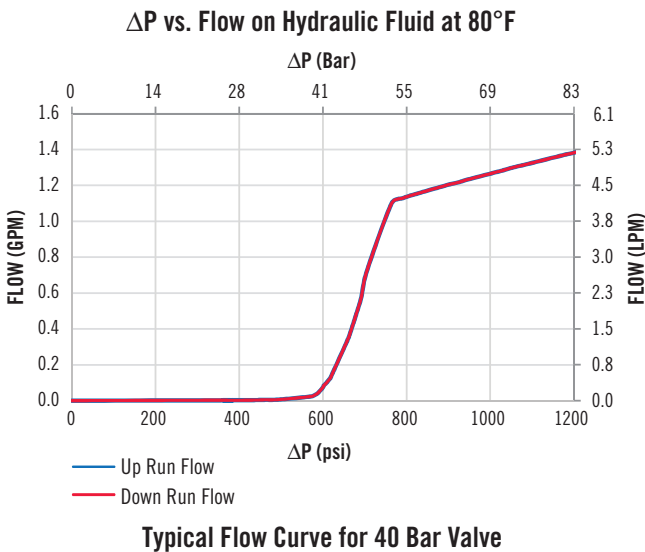

PART NUMBER	NOMINAL CRACKING PRESSURE	VALVE FLOW POINT		
		MIN. FLOW (LPM) REF.	AT (Bar)	MAX. LOHM RATE
PCHR5520020S	20 Bar (290 psi)	1.0	25	1500
PCHR5520040S	40 Bar (580 psi)	1.8	50	1200
PCHR5520060S	60 Bar (870 psi)	2.5	75	1100
PCHR5520080S	80 Bar (1160 psi)	3.0	100	1050
PCHR5520100S	100 Bar (1450 psi)	3.5	125	1000

PERFORMANCE
Full Open Lohm Rate: 650 Lohms*
Up Run Leak: Valve will flow less than 1.0 cc/min at 90% of cracking pressure.
Flow Point: Valve flow point at 125% of nominal cracking pressure (See chart left.)
Reseat: Valve will flow less than 0.05 LPM at 88% of nominal cracking pressure.
Maximum Working Pressure: 280 Bar (4060 psid) (checked direction) 280 Bar (4060 psid) (relief flow direction)
Materials: Stainless steel
All flows specified on hydraulic fluid at 80°F
*Lohm is a measure of flow resistance. See back page for more information.

LEE IMH 5.5 mm RELIEF VALVE – REVERSE FLOW

SIMPLE TO INSTALL

Insert the relief valve into a drilled installation hole. Drive the expander pin flush to within 0.25 mm (0.010 of an inch) above flush of the relief valve body. Use a maximum installation force of 625 KgF (1380 lbs. force).

The installation tool can bottom on the insert body with no consequence. Lee Installation Tool part number CCRT0900120S is available.

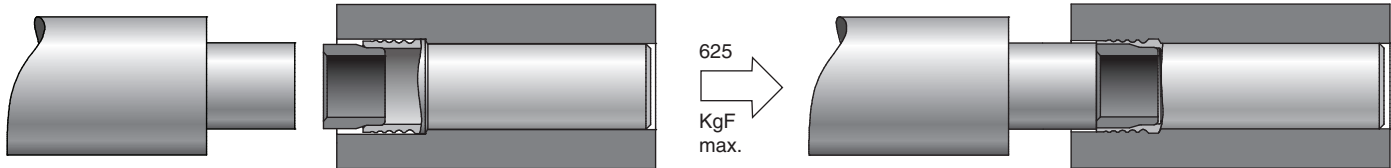

LOHM LAWS (Liquids)

Every engineer will be interested in our simple system of defining the fluid resistance of Lee hydraulic components.

Just as the Ohm is used in the electrical industry, we find that we can use a liquid Ohm or "Lohm" to good advantage on all hydraulic computations.

When using the Lohm system, you can forget about coefficients of discharge and dimensional tolerances on drilled holes. These factors are automatically compensated for in the Lohm calculations, and confirmed by testing each component to establish flow tolerances. The resistance to flow of any fluid control component can be expressed in Lohms.

The Lohm has been selected so that a 1 Lohm restriction will permit a flow of 100 gallons per minute of water with a pressure drop of 25 psi at a temperature of 80°F.

LIQUID FLOW FORMULA

The following formulas are presented to extend the use of the Lohm laws to many different liquids, operating over a wide range of pressure conditions.

These formulas introduce compensation factors for liquid density and viscosity. They are applicable to any liquid of known properties, with minimum restrictions on pressure levels or temperature.

The units constant (K) eliminates the need to convert pressure and flow parameters to special units.

$$\text{Volumetric Flow Units } L = \frac{KV}{I} \sqrt{\frac{H}{S}} \quad \text{Gravimetric Flow Units } L = \frac{KV}{w} \sqrt{HS}$$

NOMENCLATURE

- L = Lohms
- S = Specific gravity*
- H = Differential pressure
- V = Viscosity compensation factor**
- I = Liquid flow rate: Volumetric
- w = Liquid flow rate: Gravimetric
- K = Units Constant – Liquid (see chart below)
- *S = 1.0 for water at 80°F.
- **V = 1.0 for water at 80°F.

(For other fluids and temperatures, contact your Lee Sales Engineer or visit us at www.leeimh.com).

LIQUID FLOW – UNITS CONSTANT K

VOLUMETRIC FLOW UNITS			
Flow Units	Pressure Units		
	psi	Bar	kPa
GPM	20	76.2	7.62
L/min	75.7	288	28.8
ml/min	75,700	288,000	28,800
in ³ /min	4620	17,600	1760

GRAVIMETRIC FLOW UNITS			
Flow Units	Pressure Units		
	psi	Bar	kPa
PPH	10,000	38,100	3810
gm/min	75,700	288,000	28,800