



Innovation in Miniature

The Lee Company
Industrial Microhydraulics Group
22 Pequot Park Road
Westbrook, CT 06498-0424 USA
860-399-6281

Installation Procedure IP PCHF 5.5

REVISION HISTORY

Revision	Date	Change
A	8/3/2018	Initial Release

Lee Relief valve, 5.5mm Series, Insert, Forward
FACTORY INSTALLATION PROCEDURE

Table of Contents

- 1. Overview 2
- 2. Installation Hole Requirements 2
- 3. Installation 3
 - 3.1. Installation Equipment..... 4
 - 3.2. Standard Factory Installation (see Appendix 4A)..... 4
- 4. Appendices..... 5
 - 4.1. Appendix A: Diagram of Factory Installation 5
 - 4.2. 4.2 Appendix B Installation Hole 6
 - 4.3. 4.3 Appendix C Installation Tool 7

Overview

This procedure is intended to provide process guidelines for proper installation of Lee Relief Valve, 5.5 mm Series, Insert, Forward product. Section 2 provides an overview of the hole requirements. Section 3 contains the installation procedure. Section 4 contains a diagram of proper orientation and position of the product with respect to the installation hole and installation tool.

Compliance with this installation procedure will ensure optimal product performance. Please contact your local Lee Company Sales Representative for questions concerning installation of Lee Company products.

Installation Hole Requirements

The Lee Relief Valve, 5.5 mm Series, Insert, Forward product is purposely designed to perform well under adverse conditions. Therefore, the installation hole specifications outlined in this section should be followed precisely to ensure proper function of the product's expansion sealing features. Installation forces and pressure ratings are based on installations in aluminum housings or manifolds.

Installation hole specifications as found on Lee Installation Drawing 1INST056475S (Appendix B) will ensure proper operation of the Lee Relief Valve, 5.5 mm Series, Insert, Forward product. The hole should be clean, dry and free of burrs. Surface finish should not exceed 1.6 μ m (Ra) with no longitudinal surface defects. Surface finish requirements must be given special attention. The expansion section of the Lee Relief Valve, 5.5 mm Series, Insert, Forward product seals and retains the product in the hole. A smooth machined surface where the product interacts with the hole is needed to seal and retain the product properly.

The Lee Company does not recommend the use of coatings or surface treatments in the area of the installation hole where the product is to be installed. These may reduce product retention.

3. Installation

Installation Overview – All Lee Relief Valve, 5.5mm Series, Insert, Forward products use a pin to expand a grooved section of the insert's body into the housing wall to affect a seal and retain the component. The pin, which has been pre-installed, is driven into the body. The insert is pre-lubricated for proper installation. Do not clean prior to installation.

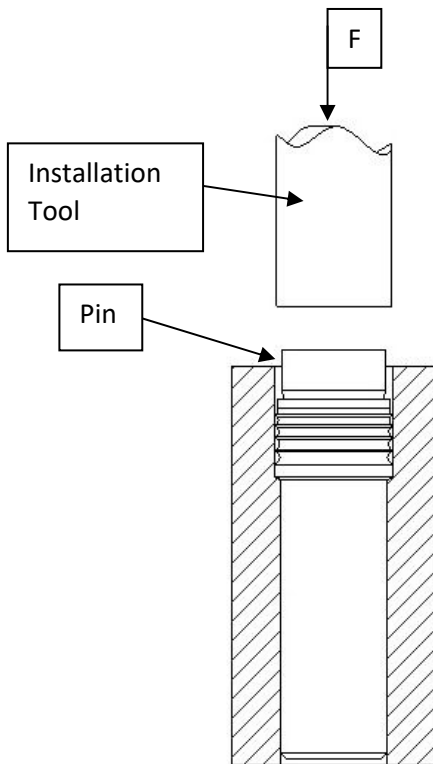

1. The Lee Relief Valve, 5.5 mm Series, Insert, Forward product is inserted into the installation hole with the pin end up as shown.

2. The installation tool (P/N CCRT0900120S) which is aligned with the installation hole, approaches the hole and contacts the back of the pre-installed pin. The tool drives the pin into the relief valve body with a force of 6130 Newtons maximum. Using friction and penetration, the lands bite into the housing material.

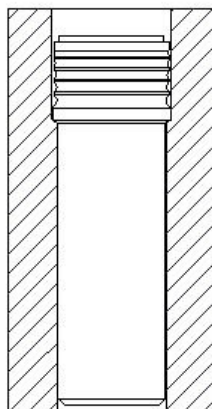

3. When the installation tool is retracted, the installed product can be inspected by measuring the depth of the pin relative to the body. This distance should be flush to within 0.25mm above flush each other.

3.1. Installation Equipment

The Lee Relief Valve, 5.5 mm Series, Insert, Forward product has been designed to be installed using pneumatic, hydraulic or servo type press equipment. The housing in which the component is to be installed should be held stationary on a solid surface. The relief valve is expanded by the insertion of the pre-installed and lubricated expansion pin using an installation tool under load. Adjust the press stroke to eliminate excess over travel as this may damage the relief valve. Adjust the press supply pressure to limit the maximum force to 6130 Newtons.

Insertion should be done using Lee Installation Tool p/n CCRT0900120S (see Appendix 4C). The tool and installation hole need to be concentric within 0.03 mm as shown in Diagram of Factory Installation Appendix 4A.

3.2. Standard Factory Installation (see Appendix 4A)

1. Firmly support the housing or manifold in which the relief valve is to be installed.
2. Insert Lee Relief Valve, 5.5 mm Series, Insert, Forward product into the installation hole, pin end up, until it is seated on the shoulder of the installation hole.
3. The installation force should be 6130 Newtons maximum using Lee Installation Tool P/N CCRT0900120S. The tool can approach the product at a rate of 20-35 mm/sec. The maximum speed of the tool during installation should be limited to 3 mm/sec.
4. Inspect the Lee Relief Valve, 5.5 mm Series, Insert, Forward product for proper installation by measuring the depth of the pin relative to the body. Installation is complete when the exposed ends (surfaces A and B) are flush to within 0.25mm above flush of each other as shown in section 4A.
5. Retract the tool and follow the same procedure for additional installations.

Factory Best Practices:

1. Examine the condition of the Installation Tool at appropriate intervals and replace if damaged or chipped.
2. Clean feed bowls once per day.
3. Turn off vibratory feed bowl when the assembly station is idle, or if the feed rail is full of parts.
4. Use the minimum vibration setting to advance valves in the feed bowl.
5. If a pneumatic tube transport is used to feed the relief valve into the assembly area from the feed rail, minimize the air pressure used to transport the relief valve to prevent possible damage to the valve.

Appendices

Appendix A: Diagram of Factory Installation

(Section View of Hole, Forward Insert Product and Installation Tool)

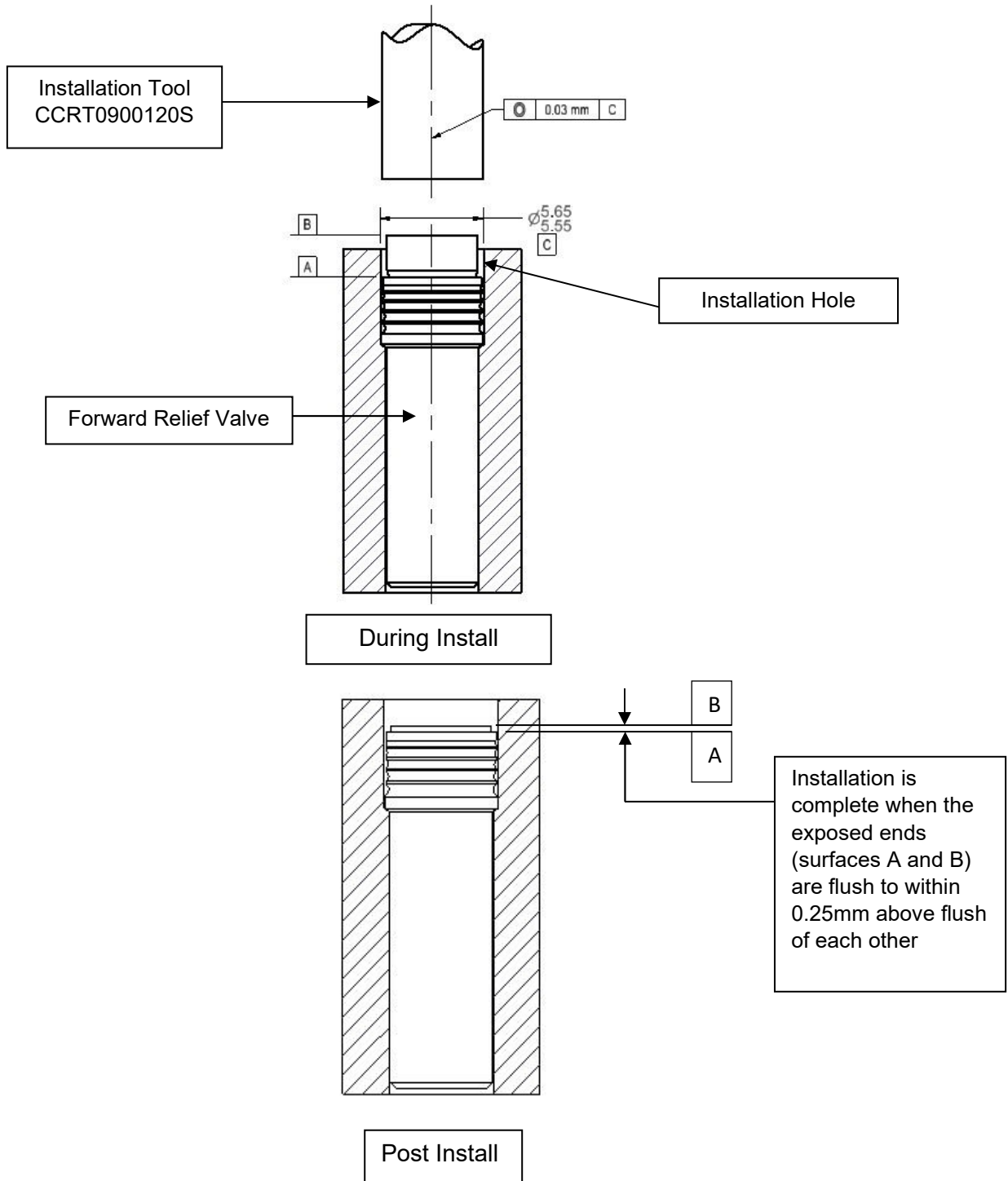

Appendix B: Installation Hole

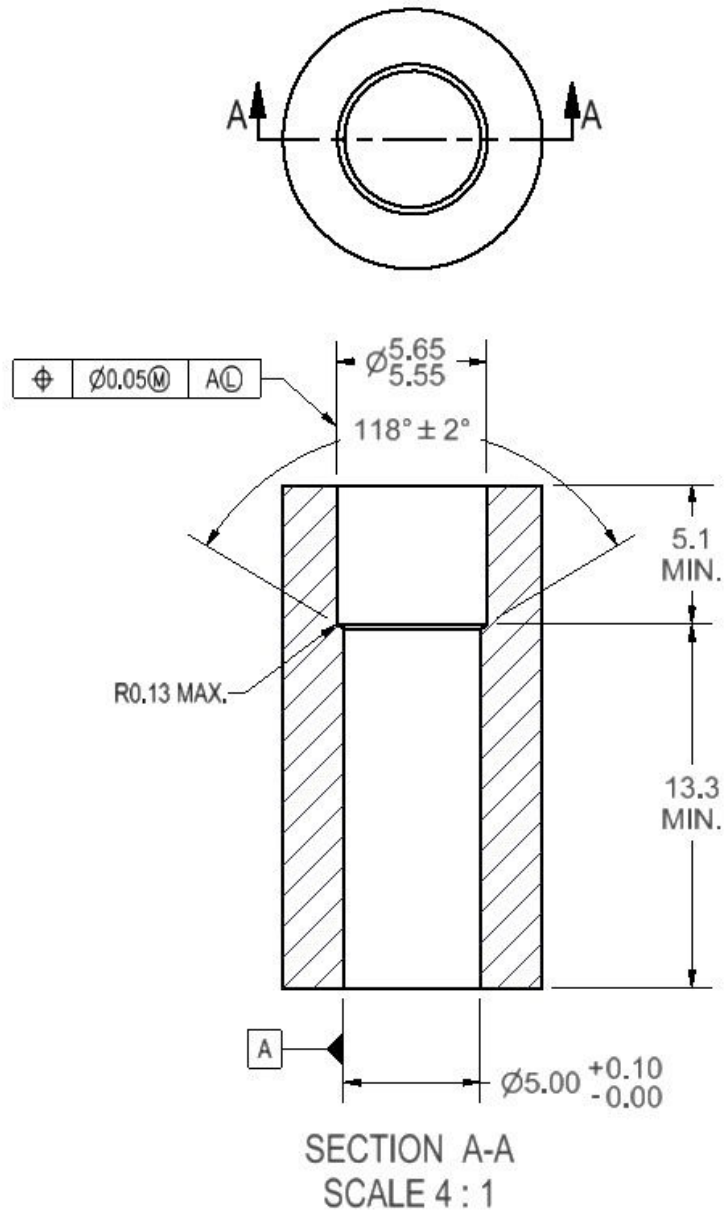

DIMENSIONS IN MILLIMETERS

Hole should be clean, dry and free of burrs. No longitudinal surface defects permitted. No coatings or surface treatments in the area of the installation hole where the product is to be installed.

Refer to Lee Drawing No. 1INST056475S for complete specifications.

Appendix C: Installation Tool

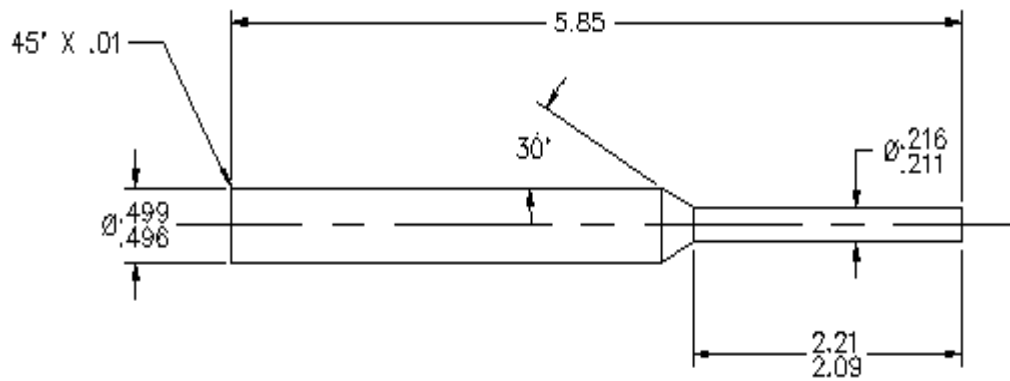

DIMENSIONS IN INCHES

Refer to Lee Part No. CCRT0900120S for complete specifications.